

LUOKITUSTODISTUS
HOMOLOGATION FORM

Luokitus N°

2/KF6/2014

01/VO/14

Luokitukseen voidaan tehdä muutoksia Karting lajiryhmän toimesta ja luokitusmuutokset tulevat voimaan joko välittömästi tai lajiryhmän ilmoituksen mukaan.

AKK-Motorsport Ry

Homologation can be modified by the Karting Committee. The modifications will become valid either immediately or the informed time.

MOOTTORI / ENGINE
KF6

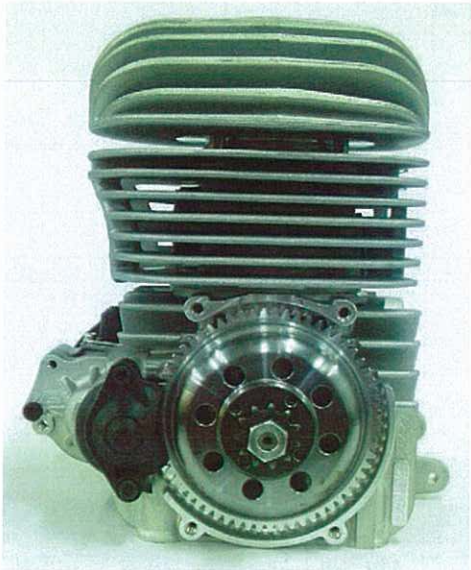
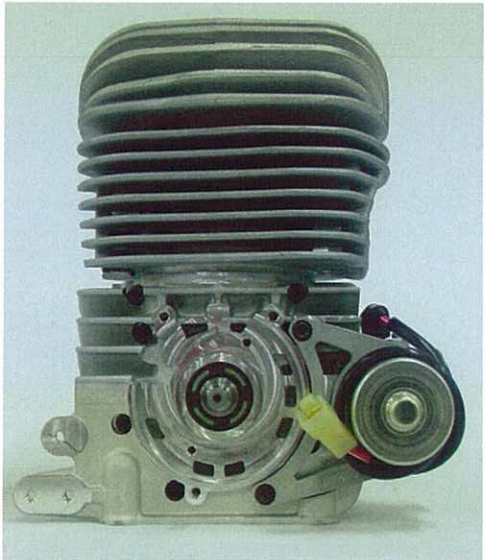
Valmistaja	Manufacturer	Vortex
Malli	Model	MR 2
		
MOOTTORIN OIKEA PUOLI PHOTO OF THE RIGHT SIDE OF THE ENGINE	MOOTTORIN VASEN PUOLI PHOTO OF THE LEFT SIDE OF THE ENGINE	

Allekirjoitus ja leima AKK-Motorsport

Signature and stamp of the AKK-Motorsport



TEKNISET TIEDOT		TECHNICAL INFORMATION	
A	ARVOT	A	CHARACTERISTICS
			Tolerance
Iskutilavuus	<i>Volume of cylinder</i>	60 CC	
Alkuperäinen sylinterin halkaisija	<i>Original Bore</i>		
Sylinterin maksimi halkaisija	<i>Theoretical maximum bore</i>	42.10 MM	
Iskunpituus	<i>Stroke</i>	43 MM	
Jäähdytysjärjestelmä	<i>Cooling system</i>	ILMA/AIR	
Kaasuttimien lukumäärä	<i>Number of carburation systems</i>	1	
Huuhtelukanavien määrä	<i>Number of transfer ducts, cylinder/sump</i>	2	
Pakokanavien määrä	<i>Number of exhaust ports / ducts</i>	1	
Kiertokangon pituus silmukoiden keskeltä	<i>Length between the axes of the connecting rod</i>	87 MM	±0.2mm
Kampiakselin paino	<i>Weight of the crankshaft</i>	1250 GR	+/- 3%
Palotilan koko	<i>Volume of combustion chamber</i>	6,8 CM³	minimum
Männän paino, ilman männänrengasta	<i>Piston weight without ring</i>	57 GR	+/- 10 g
Männänrenkaiden määrä	<i>Number of piston rings</i>	1	

B	Maksimiasteluku (0.20 mm mittaliuska, 10mm leveä)	B	OPENING ANGLES
	<i>Pakoaukko max</i>	156°	
	<i>Imuaukko max</i>	144°	

C	MATERIAALIT	C	MATERIAL
Sylinteri	<i>Cylinder</i>	ALUMIINI / TERÄS	
Sylinterin kansi	<i>Cylinder head</i>	ALUMIINI	
Alakerta	<i>Sump</i>	ALUMIINI	
Kiertokansi	<i>Connecting rod</i>	TERÄS	

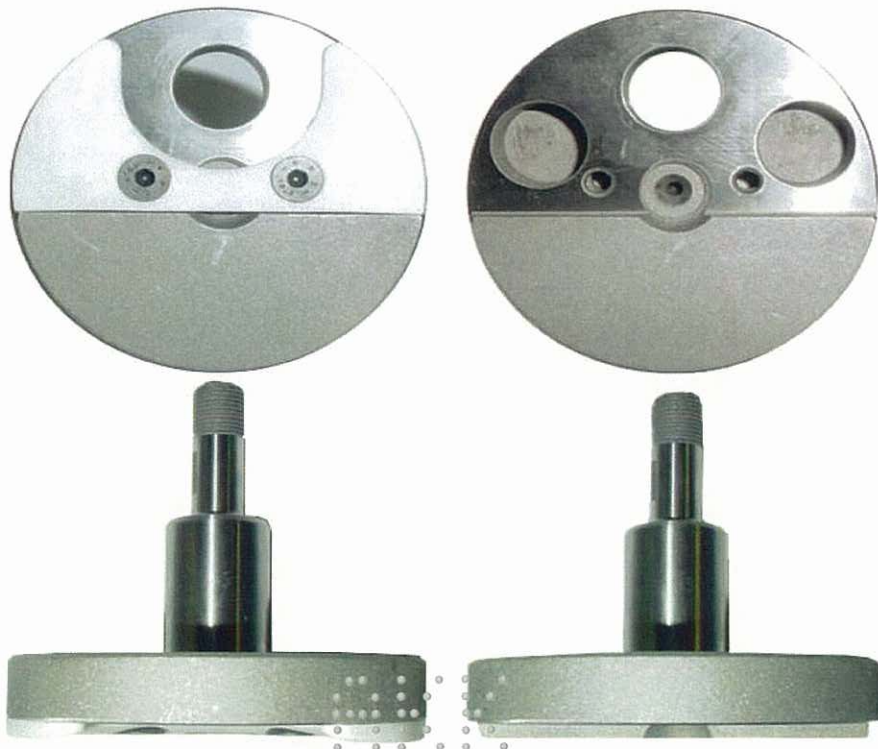

Vanha kiertokanki**Uusi kiertokanki****Vanha kampiakselin puolikkaat**

Uusi kampiakselin puolikkaat



Vanhan kampiakselin piirros

Uuden kampiakselin piirros

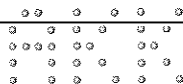
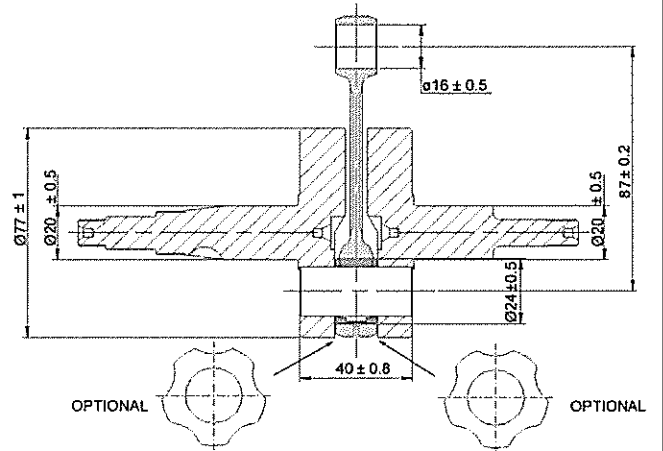
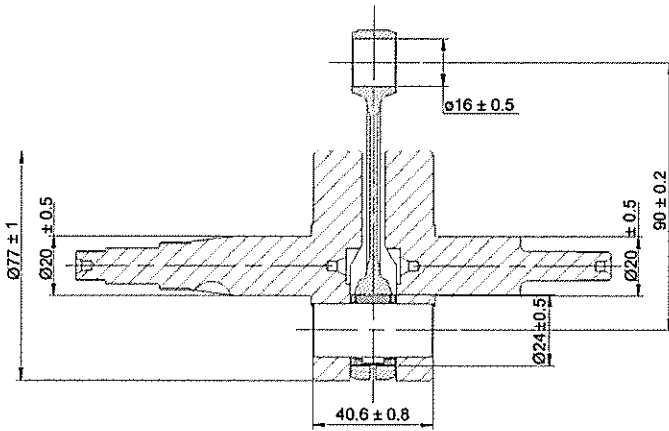

Vanha sylinterikansi



Uusi Sylinterikansi



Vanha sylinterikansipiirros

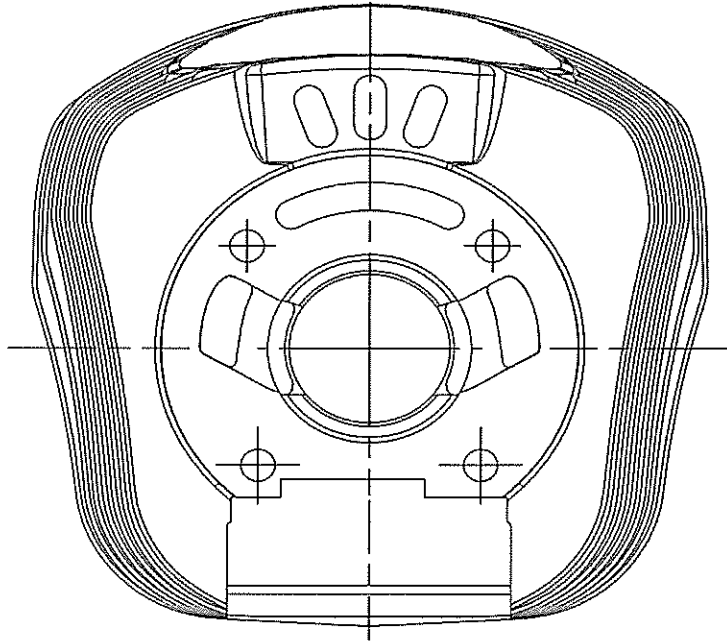

Uusi sylinterikansipiirros

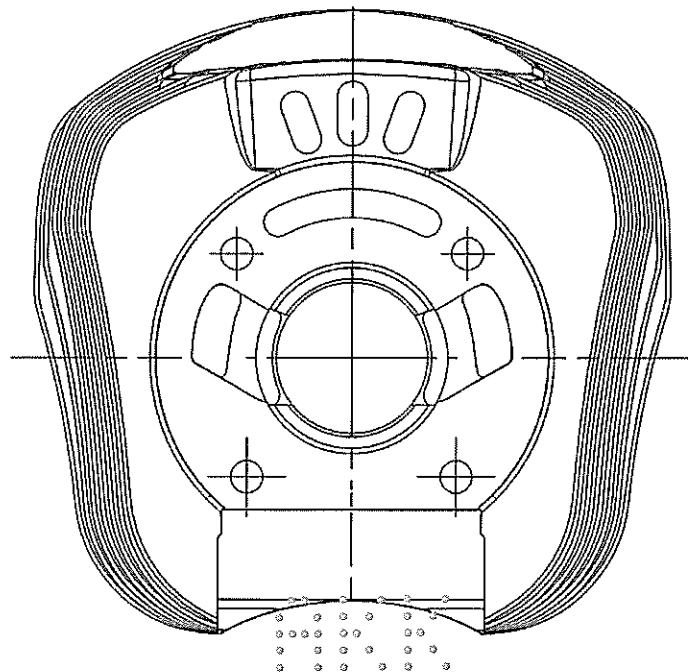

2/KF6/2014
01/VO/14

Vanha sylinteri levityskuva

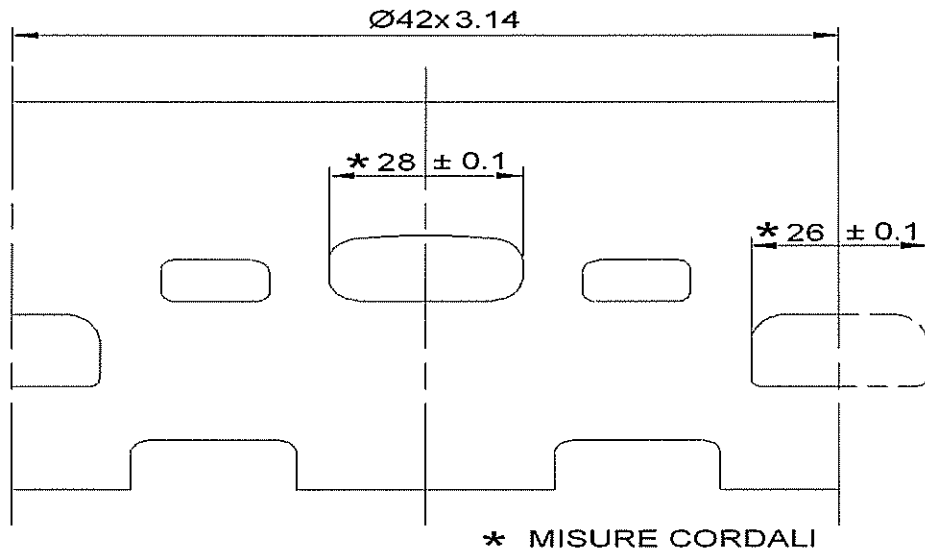

Uusi sylinteri levityskuva

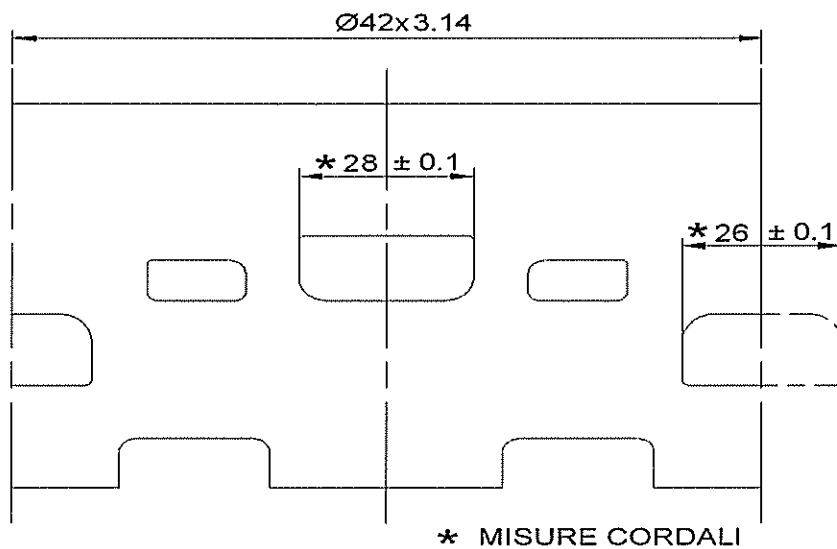

Vanha sylinteripiirros

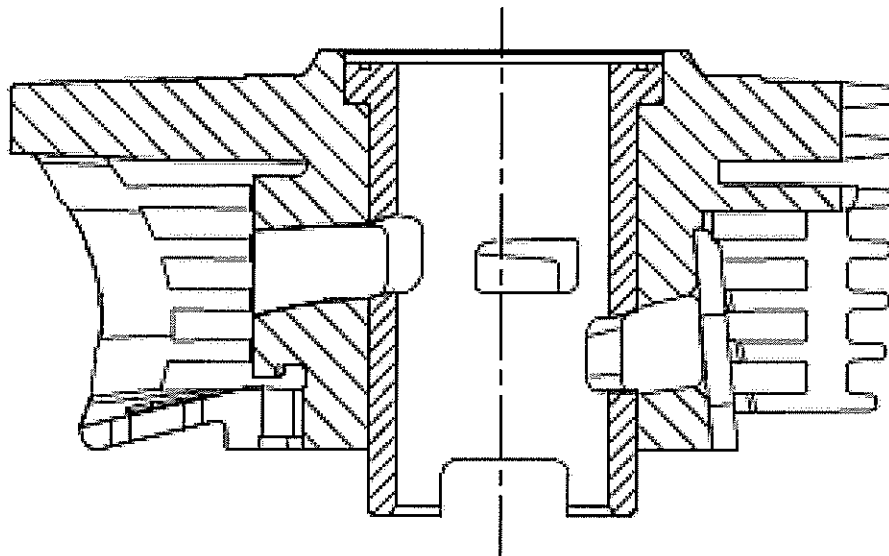

Uusi sylinteripiirros

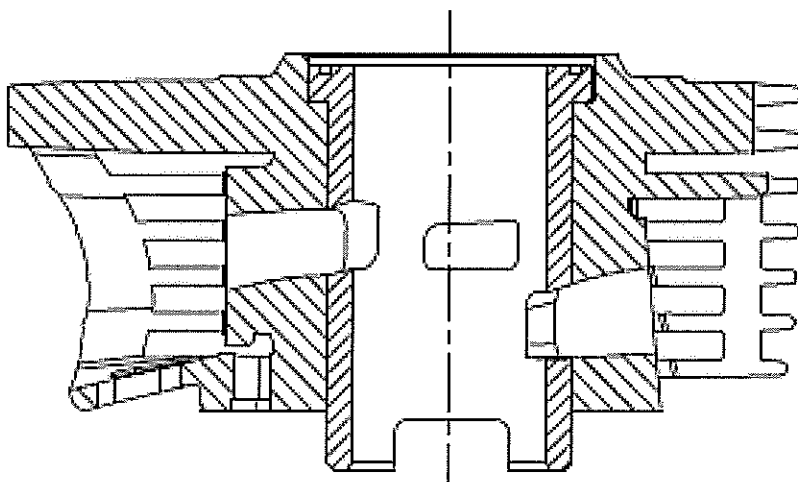

Vanha sylinteripiirros

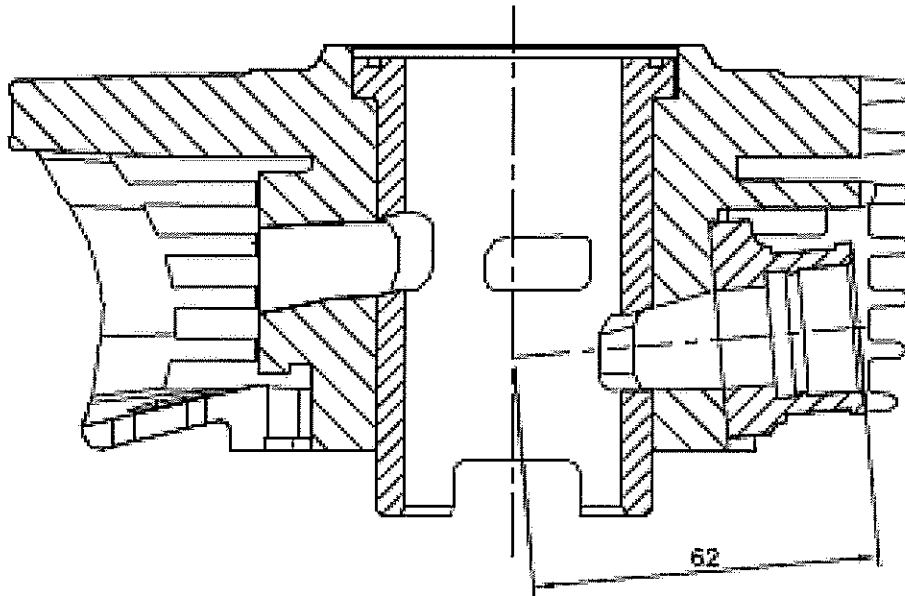

Uusi sylinteripiirros

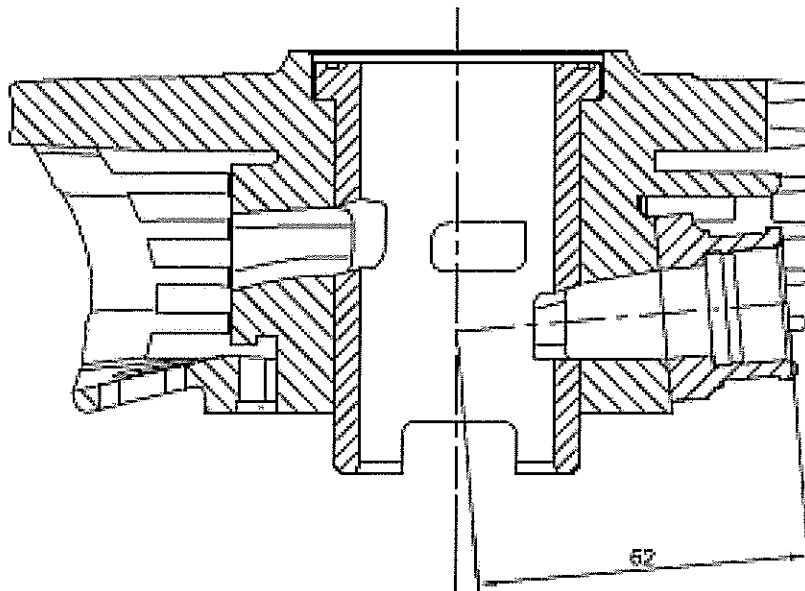

Vanha sylinteri alapuolelta kuva



Uusi sylinteri alapuolelta kuva

