

LUOKITUSTODISTUS HOMOLOGATION FORM

1/KF6/2014

Luokitukseen voidaan tehdä muutoksia Karting lajiryhmän toimesta ja luokitusmuutokset tulevat voimaan joko välittömästi tai lajiryhmän ilmoituksen mukaan.

AKK-Motorsport Ry

Homologation can be modified by the Karting Committee. The modifications will become valid either immediately or the informed time.

SYTYTYSLAITTEISTO / IGNITION SYSTEM KF6

| | | |
|------------|--------------|--------------------|
| Valmistaja | Manufacturer | SELETTA SRL |
| Malli | Model | LC 23915 |



SYTYTYSLAITTEET

PHOTO FROM
IGNITION SYSTEM

Allekirjoitus ja leima AKK-Motorsport
Signature and stamp of the AKK-Motorsport



KÄÄMI JA ROOTTORI
PHOTO OF THE ROTOR ASSY



ROOTTORIN JA KÄÄMIN PIIRRETUS

DRAWING OF THE ROTOR ASSY

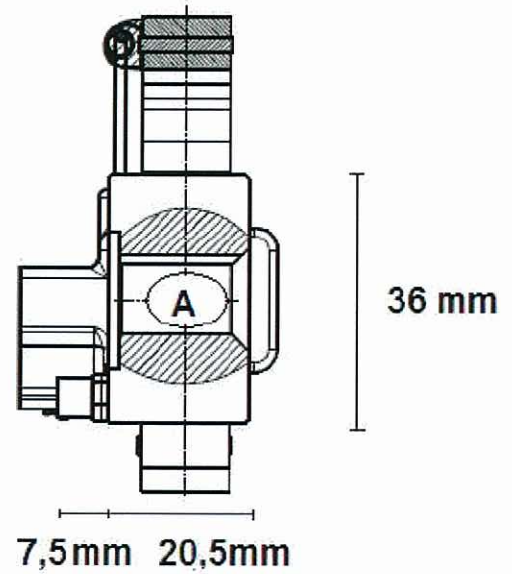
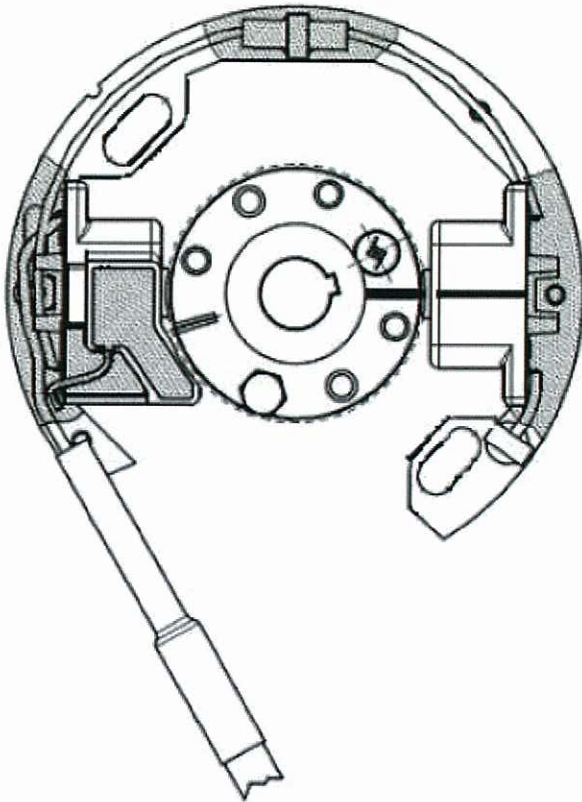

Peso 98 +/- 10 gr.

A = cono cilindrico d.10

A = cono cilindrico d.12

A = cono conico 1:5

PUOLAN PIIRRETUS

DRAWING OF THE COIL

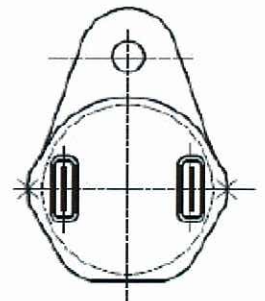
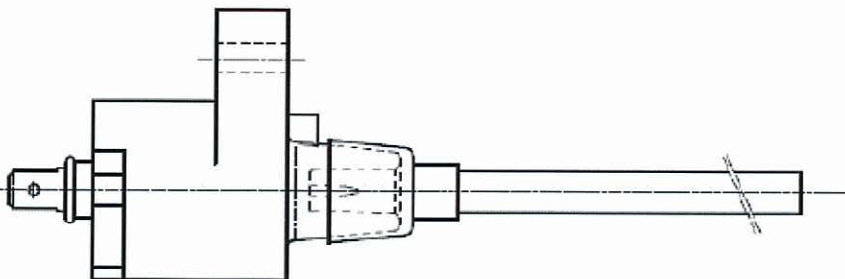

KYTKENTÄKAAVIO PIIRROS

DRAWING OF THE ELECTRICAL SCHEMA

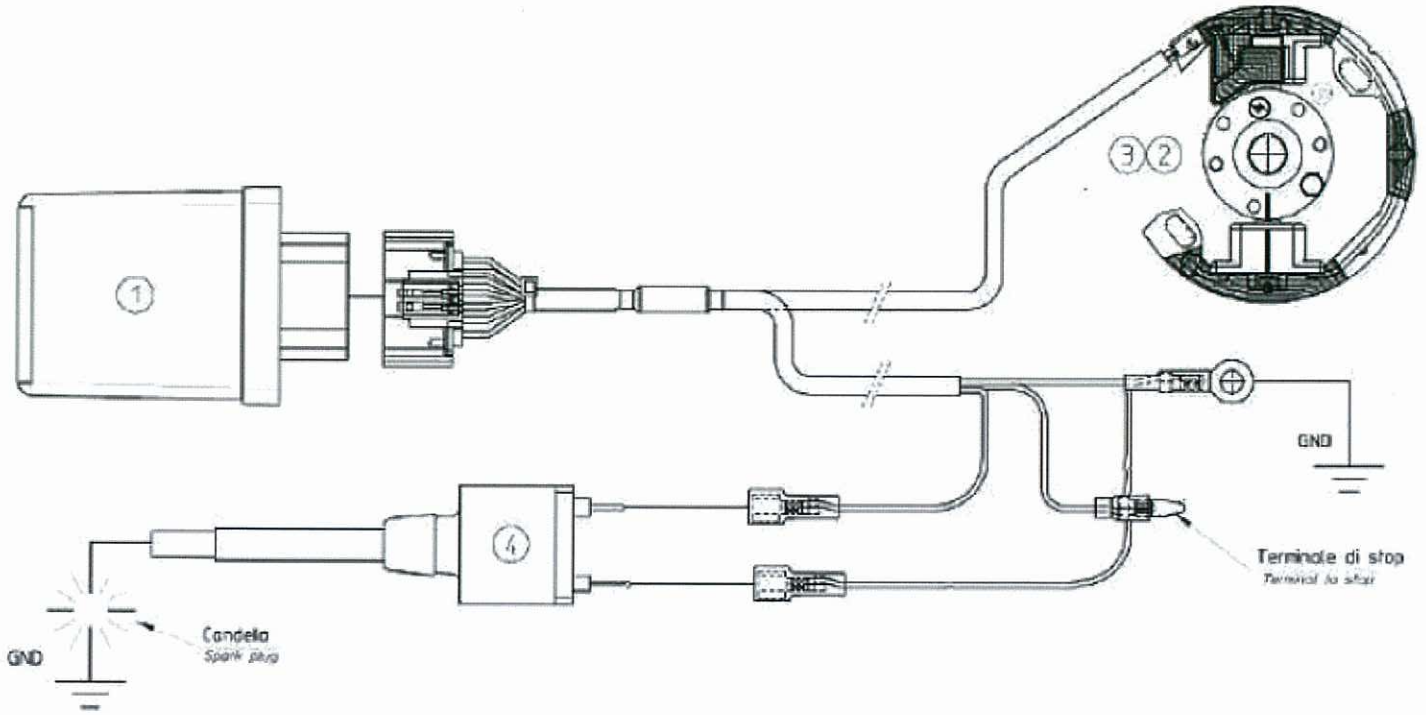

ENNAKKOKÄYRÄ

DRAWING OF THE ADVANCE CURVE

